

WGR

Circular weather resistant louver in aluminium with frame and protecting screen

Best.-Nr.

262

Order example

Best.-Nr.	ø d ₁ [mm]
262	200

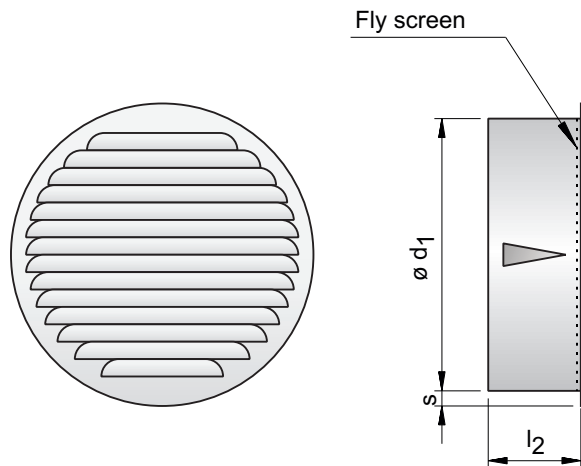

ø d ₁ [mm]	l ₂ [mm]	s [mm]	Gewicht Poids Weight [kg]	Preis brutto Prix brut Price gross
80	45	12,5	0,062	
100	45	14,0	0,090	
125	45	14,0	0,117	
150	45	14,0	0,150	
160	45	15,0	0,175	
180	45	16,5	0,235	
200	45	14,5	0,250	
224	45	19,0	0,340	
250	55	14,0	0,360	
280	55	16,0	0,445	
300	55	13,5	0,464	
315	55	15,0	0,464	

Tender text:

Round weather protection grille WGR, make: Aerotechnik E. Siegwart, made of aluminium Al 99.5 and push-fit spigot for insertion into spiral duct, special blade design with low pressure loss, blade division ca. 10 mm, with fly screen made of galvanised steel (mesh size ca. 1.8 x 1.8 mm). Free cross section 40%.

Remark: not available lacquered



Aerotechnik E. Siegwart GmbH
Untere Hofwiesen • D-66299 Friedrichsthal
☎ +49 (0) 6897/859-0 • 📠 +49 (0) 6897/859-150
www.aerotechnik.de • info@aerotechnik.de

Diagramm1: Pressure loss of the weather louvre in the exhaust air

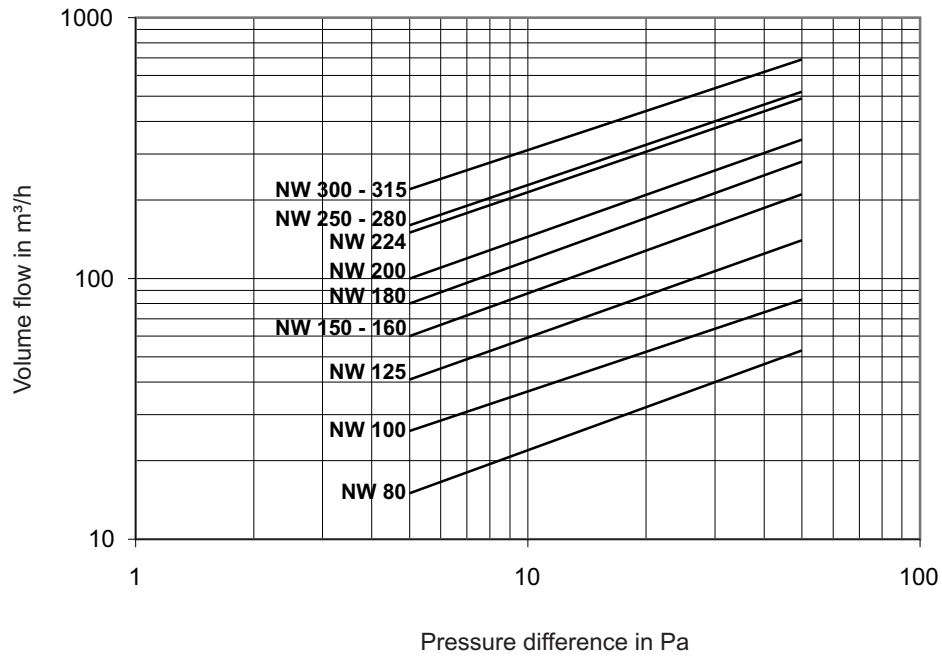

Diagramm1: Pressure loss of the weather louvre in the supply air

